

DMIMS-DX™

Digital Metal Impact Monitoring System

Repair,
Replacement,
and
Automation
Services

Westinghouse Repair and Replacement Services (RRS) has developed the *DMIMS-DX™* Digital Metal Impact Monitoring System to provide fast, reliable detection of loose parts impacts within the Reactor Coolant System (RCS), while minimizing the generation of false alarms. Utilizing our more than 35 years of experience in loose parts monitoring, including extensive field support of loose parts evaluations, we have greatly enhanced and extended the capabilities of the previous Westinghouse DMIMS System. This advanced system employs the latest digital technology and offers significant operational advantages.



(Continued on back)



For more information, call your local Westinghouse Electric Company sales representative.

Overview

The *DMIMS-DX*[™] System is entirely compatible with the older model Westinghouse DMIMS and can use the same front-end electronics and hardware (accelerometers and preamplifiers). Through the utilization of digital signal processors and personal computer technology, the *DMIMS-DX*[™] can provide continuous and automatic data reduction, as well as display all essential information to plant staff in a clear and concise manner. The *DMIMS-DX*[™] System reduces data to meaningful terms that can be evaluated quickly and easily to determine the proper course of action.

Loose parts monitoring is based on listening for the impact of loose parts against fixed components within the primary system as they are propelled by the coolant flow. This application appears simple on the surface, but its effective implementation is not an easy task. The noises typical of an operating plant can generate false alarms that reduce operator confidence, interfere with normal operations, and cause unnecessary expense. The Westinghouse DMIMS System uses a patented algorithm for the determination of the metallic characteristics typical of loose parts. This algorithm and the associated alarm algorithms together minimize the generation of false alarms and have established a reputation for reliability within the industry.

Improvements

The newly developed *DMIMS-DX*[™] system uses the same patented impact detection algorithms and alarm criteria, but improves upon the older DMIMS in several significant areas. Analog recording has been replaced by high-speed digital capture to disk and tape of both the analog signals and their respective setpoint data. Included in the new human-machine interface software is the ability to do frequency spectrum analysis and arrival-time measurements on the captured signals, providing the plant personnel with the ability to do many mass analyses and location calculations. When additional data evaluations, safety analyses, or part retrieval planning is required, the captured, digitized data can be transferred to Westinghouse electronically for analysis and

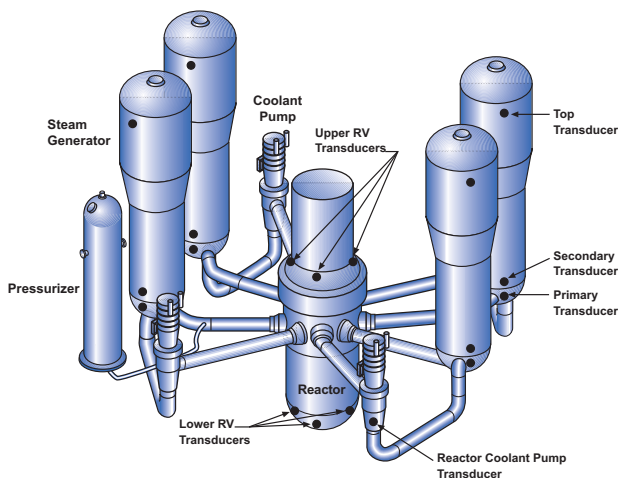

response in 24 hours or less. Thus, the utility retains the benefit of Westinghouse expertise, but with less incurred time and costs from data evaluations.

Theory of Operation

Metal objects can be introduced into the RCS in a number of ways. Typical sources include refueling and inspection tooling, repair tooling and parts, and failures in RCS components and internals. With the velocity of the coolant flow typically around 50 ft/sec or 15 m/sec, these objects can be swept along into natural collection areas where the coolant flow is divided, such as the hot leg channel head of a steam generator or the bottom of the reactor vessel. They can strike reactor walls and internal structures with considerable force and cause significant damage if not detected and removed.

The impact of a metal object on RCS walls or structures generates an acoustic wave that can travel long distances through the reactor and pipe walls. Research programs have shown that the impact excitation generates a very wide band acoustic signal, that wide band accelerometers make good acoustic sensors, and that the audio frequency range of 1 kHz

Core Barrel Vibration Monitor (CBVM)

In a pressurized water reactor (PWR), the reactor core is surrounded and supported by the core barrel, which is supported entirely at its top end. Core motion is primarily due to cantilever beam motion of the core barrel. The shielding effect of the reactor coolant on the neutron flux exiting the core changes as the core moves closer to or further from the pressure vessel wall. Thus, the neutron flux detected by a Nuclear Instrumentation System (NIS) ex-core power range detector is modulated by core movement.

The Core Barrel Vibration Monitor detects lateral core barrel motion by processing these signals from the NIS power range channels. In the case of multi-section power range detectors, only one section of each detector, usually the lowest section, needs to be used for the purpose of core barrel monitoring.

The neutron noise present on the signal from an individual power range detector provides a general measure of core barrel motion. In addition, the signals from pairs of detectors, primarily the detectors on opposite sides, (180 degrees apart), can be combined in the calculations to get a better measure of the magnitude and direction of horizontal core barrel motion.

Neutron noise measurements may assist in diagnosing the following problems:

- Loss of preload of the core barrel hold-down spring
- Loss of thermal shield support integrity
- Flow abnormalities in the upper and lower core

to 20 kHz is a good range—where reactor background noise is not too great and attenuation of sound in the reactor walls is not too severe.

The sensitivity of impact detection can be maximized by placing sensors as close as possible to the areas where loose parts tend to be captured. With a larger number of sensors, much more detailed impact source locating calculations may be performed. Other calculations, such as estimating the mass of the impacting object, also become easier.

DMIMS-DX™ Highlights

Impact Detection & Recording

The Westinghouse *DMIMS-DX™* System:

- Uses a patented algorithm for impact detection and false alarm minimization
- Allows impact detection and alarming even upon a single CPU or DSP circuit board failure as a result of the modular, fault-tolerant design
- Features high-speed digital data capture
- Records every impact

Source Location Calculation and Mass Analysis

- Time trace and frequency spectrum analyses are available on-line
- Plant personnel can perform initial evaluation

Remote Data Transfer Capability via Internet

- The time and expense associated with shipment of analog magnetic tapes is eliminated
- Feedback of initial results from Westinghouse can be expected within 18 to 36 hours

Additional Features

The Westinghouse *DMIMS-DX™* System:

- Is upward compatible from the older model Westinghouse DMIMS or from the analog MIMS
- Can easily be mounted in existing cabinets
- Allows for easier data storage, evaluation, and communication
- Has accelerometers that have higher sensitivity with wider frequency response than most others, mount more easily, have a higher torque mounting stud, and have a large connector for in-containment ruggedness
- Automatically performs self-testing, normally every 24 hours
- Detects control rod motion commands and automatically inhibits alarms during control rod stepping
- Has an easy, graphical user interface

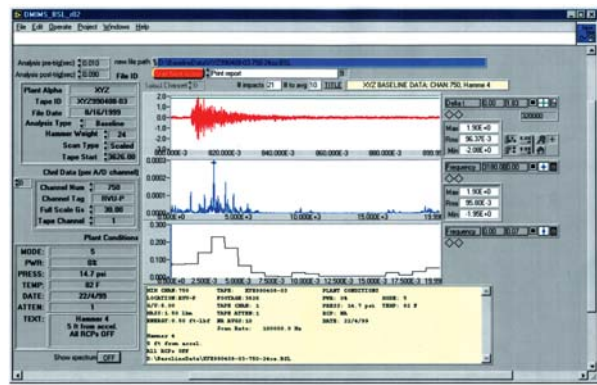

Regulatory Requirements and Industry Guidelines

The Westinghouse *DMIMS-DX™* is designed to meet or exceed the requirements of US Nuclear Regulatory Commission Regulatory Guide (RG) 1.133. The *DMIMS-DX™* can also meet or exceed the guidelines of section 14 of the EPRI report NP-5743 *Loose Parts Monitoring System Improvements*, and ASME OM-S/G-1997 Part 12, *Loose Part Monitoring In Light-Water Reactor Power Plants*, which recommend additional monitoring locations beyond the minimum RG 1.133 requirements. The additional sensors can be very useful for impact signal analysis, providing for better mass estimation and much better source location calculations.

Westinghouse Experience

Westinghouse has over 35 years of experience in loose parts and neutron noise monitoring technologies. The first Westinghouse loose parts system using accelerometers and neutron noise measurements to evaluate reactor internals was used in the late 1960s. Westinghouse applied for its first patent using analog loose parts monitoring technology in 1970, has since installed over 30 MIMS Systems worldwide, and has obtained several additional patents on metal impact monitoring.

Westinghouse is uniquely qualified because of its detailed knowledge as an Original Equipment Manufacturer (OEM) of Nuclear Steam Supply Systems. Westinghouse has conducted extensive first-of-a-kind plant vibration measurement programs, reactor vessel internals scale model flow vibration testing, and plant start-up vibration measurements. Westinghouse also has an extensive computerized database of neutron noise signals that can support development of a baseline for in-service surveillance of core internals vibrations. As with the direct vibration measurements, this database includes signals from most Westinghouse internals designs in a form that facilitates comparison, trending, etc. Westinghouse also has a service staff that is available on call 24 hours a day to support utilities with loose parts and neutron noise analysis. Further support is available through the Foreign Object Removal Group to assist in the removal of loose parts.

Support Services for *DMIMS-DX™* and *CBVM*

DMIMS-DX™ and *CBVM* are backed up with the support of full-range services, including:

Installation
Repair

Training
Signal analysis

Calibration
Impact source evaluation

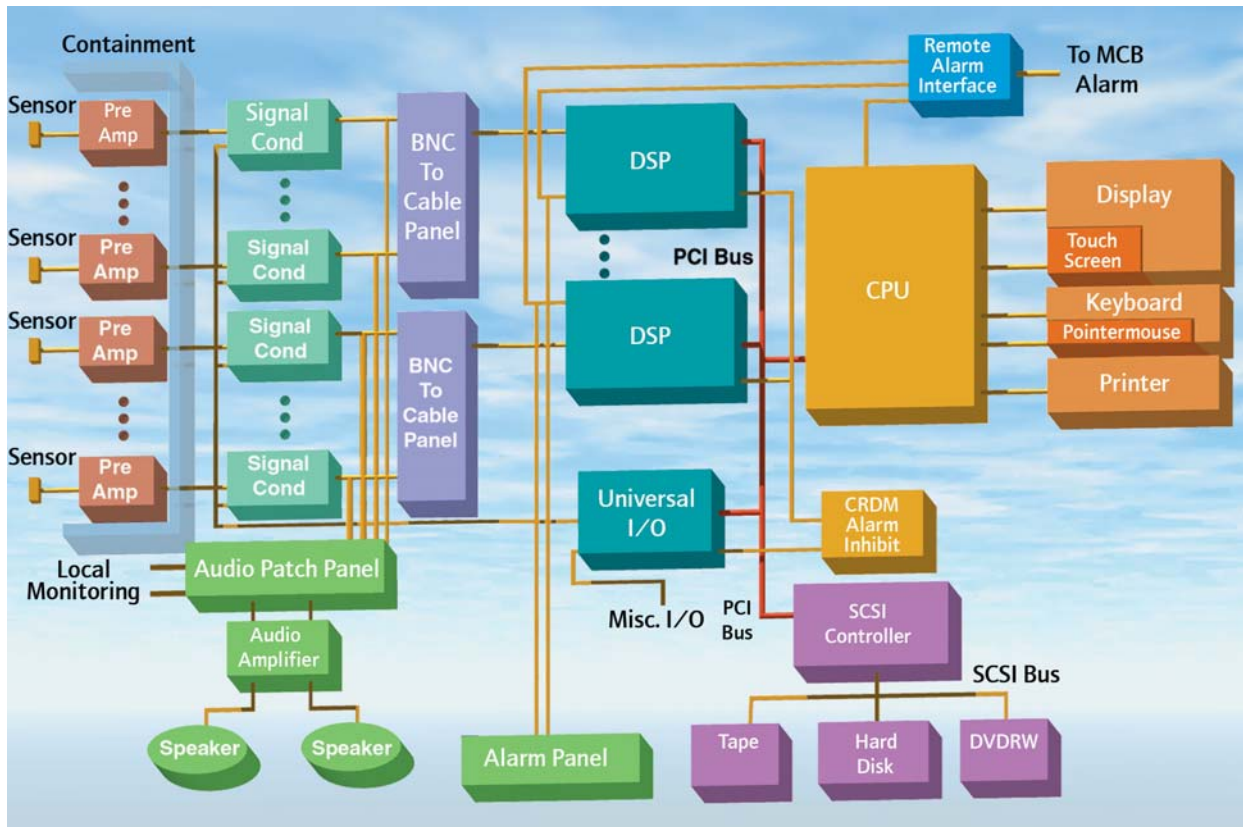

Westinghouse Electric Company
Box 355
Pittsburgh, PA 15230

www.westinghousenuclear.com

January 2005